



## MOUNTING INSTRUCTIONS FOR Part 393-540 GL1100 DRIVER FLOORBOARDS

Quantity	Description
1	Right-hand Floorboard Support w/Heel Rest
1	Left-hand Floorboard support w/ Heel-Toe Shifter
1	Engine Stud w/Nuts and Washers
2	Exhaust Stud Hanging Brackets
1	Floorboards
1	Side-stand Extender

Quantity	Descriptions
4	1/4" x 2" Bolt Sets
2	1/4" x 3/4" Bolt Sets
5	7/16" Flat Washers
4	5/16" Flat Washers
1	3/8" Spacer
1	1/2" Spacer
6	1/2" Flat Washers

Note: Read instructions thoroughly before installing.

1. Place bike on center stand. Remove the rider foot pegs, the front lower engine mounting stud and the nut from the rear stud of the front exhaust pipe on each side of the bike.

2. A brake pedal with a rubber pad is provided in the kit to use on your stock brake pedal. Using the template shown as a guide, drill two 3/16" holes from the bottom of the stock pedal pad. Then fasten the new brake pedal using the "keps" nuts provided.

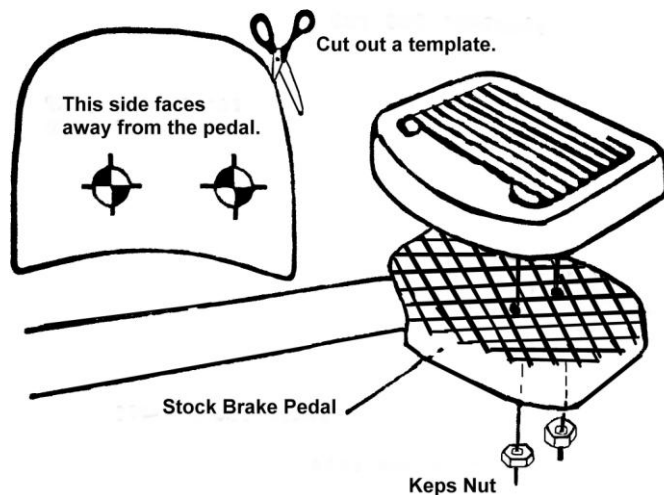

3. Remove the right side cover. Adjustment of the stock brake pedal height is required to clear the floorboard during normal use. Just loosen the jam nut that secures the clevis on the threaded shaft. Then remove the clevis pin. Now turn the clevis seven (7) half-turns down, re-install the clevis pin and cotter pin and retighten the jam nut securely. Remove the brake light switch spring from the pedal and switch. Cut and re-bend as shown and then reinstall.

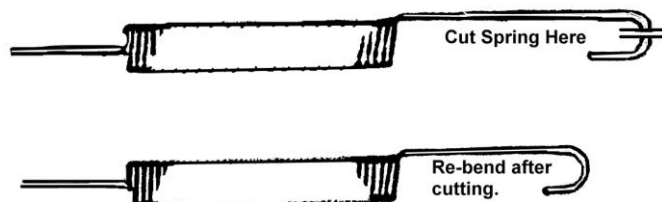

4. Place two 5/16" flat washers on each exhaust stud that you have removed the nuts and then install the exhaust stud hanging brackets. Secure loosely with the stock nuts.

## MOUNTING INSTRUCTIONS FOR Part 393-540 GL1100 DRIVER FLOORBOARDS

5. Insert the new engine stud provided through the right side engine mount plate and then install the right hand floorboard support. Fasten the rear mounting plate using the 3/8" spacer and stock foot peg bolt and washer. Do not tighten. If your bike has an interstate type guard, install two 7/16" washers between guard and floorboard bracket. If there is not guard, use three 1/2" flat washers between the frame and floorboard bracket.

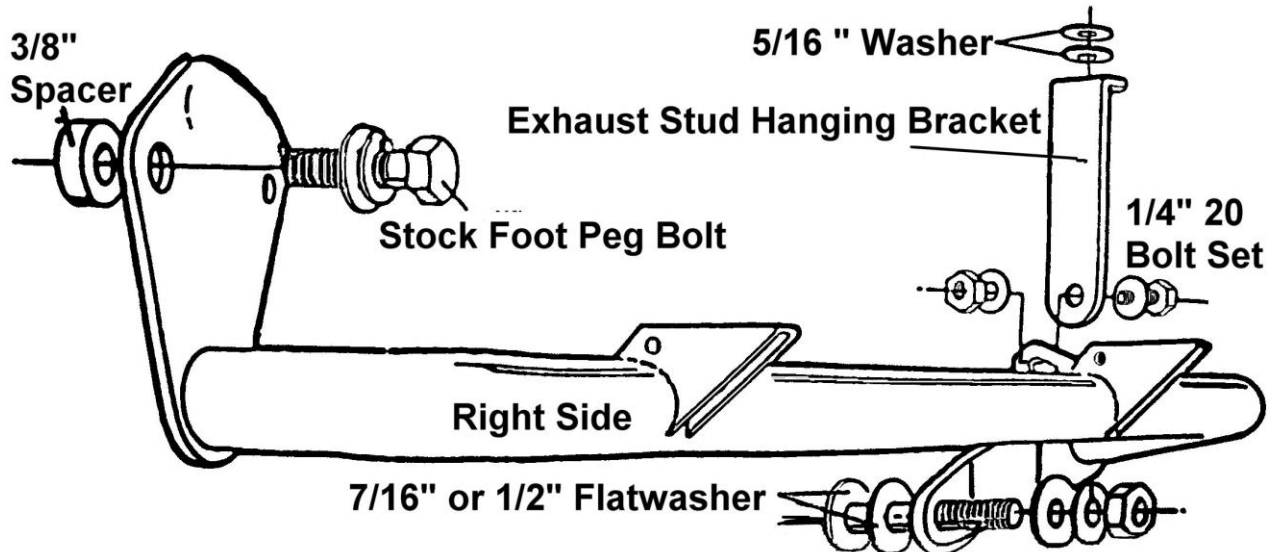

6. Remove the stock shifter rubber and cut off the two inside rings. (This makes room for the heel-toe shifter fork.) Mount the left hand floorboard support by sliding the shifter fork onto the clear area on the stock shift pedal. Secure the rear mount to the stock foot peg using the 1/2" spacer, one 7/16" flat washer and the stock lock washer and acorn nut. Leave loose.

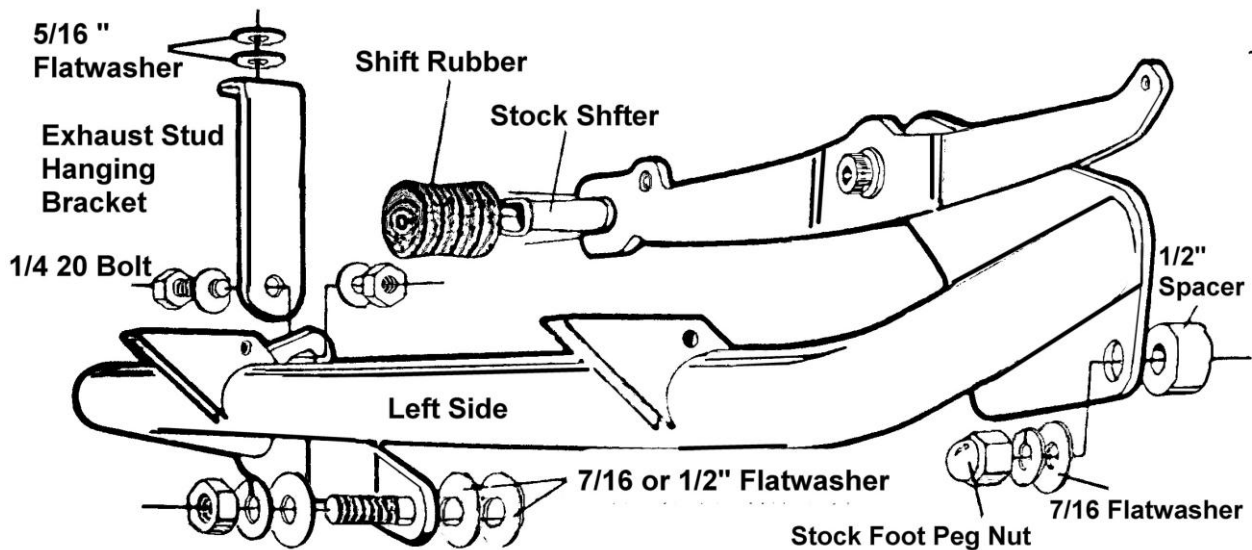

7. Finally, fasten the exhaust stud hanging brackets to the front side of the slotted tabs on the floorboard supports using the 1/4 20 x 3/4" bolt sets. (On GL1000 only, the hanging bracket may require mounting to the backside of the slotted tabs.) Tighten all nuts and bolts securely.

8. Install the floorboards.