



Instructions for Part 45-1694A GL1800 12-16 Amber LED Side Logo Accents with Running and Turn Signals



Pre-Instructions Notes:

- Read Instructions completely prior to starting.
- OEM logo emblems not included.
- Test lights for proper operation prior to installation.
- For safety, always disconnect the battery negative cable prior to starting work on your motorcycle.
- Recommend consulting the service manual prior to and during motorcycle disassembly and assembly.
- When routing wires, be sure they do not interfere with the proper and safe operation of the motorcycle.
- Wiring this part, 45-1694A, to the front directional/running lights is only a recommendation. You may also connect to an auxiliary switch or circuit as you see fit.
- *If you feel that you can not install this accent, seek a qualified mechanic.*

1. Remove logo emblem. Use **caution** when removing emblem from the bike so as to not over heat or scratch paint or emblem. Heat emblem with heat gun and pry off bike using small hook or machinist scribes. Use a rag between hooks and bike to prevent scratching and chipping of paint. *(We are not responsible for damage to the logo emblem or motorcycle while removing, cleaning or reinstalling.)*

2. After logo emblem is removed, completely clean where the emblem was located on the bike and the back of logo emblem with a cleaning product such as Goo Gone and wipe with alcohol swab provided.

NOTE: The following component removal procedures can be found in Chapter 2 of the GL1800 2012 Honda® Motorcycle Service or an online manual from such services that provide them.

3. Release tabs attaching the left/right mirror boots to the front fairing and roll back to expose front turn signal/running light wiring.

4. Remove left/right faring trim, left fairing pocket and right switch panel (Figures 1, 2, 3).

5. Push wires from chrome logo trim into the hole where the logo was located (Figure 4) and up to meet the wires leading to the front turn signals. Attach the black wire to any appropriate ground on the bike.

6. Connect logo trim wires to the bike wiring system as indicated:

LED LOGO TRIM WIRING

Black - Ground
Yellow - Running
Red - Turn Signal

BIKE WIRING

Left Side	Right Side
Orange/White - Running	Blue/White - Running
Orange - Turn Signal	Light Blue - Turn Signal

7. Check placement of LED logo trim and then thoroughly clean the location on the bike. Remove backing from double sided tape on LED logo trim, put LED logo trim on pre-determined location and press onto the bike. Hold for 30 seconds to ensure proper seating.

8. Thoroughly clean inside the LED logo trim where the logo or other emblem will go. Remove one side of the backing from the double sided tape provided and apply to LED logo trim as shown in Figure 5. Repeat with other half.

Instructions for Part 45-1694A GL1800 12-16 Amber LED Side Logo Accents (continued)

9. Remove backing from double sided tape and press logo/emblem into place in the LED logo trim. Hold in place for 30 seconds to ensure proper seating.

NOTE: - Do not ride motorcycle for one hour while adhesive on double sided tape cures.
- Do not wash or ride motorcycle in the rain for at least 24 hours.

Figure 1

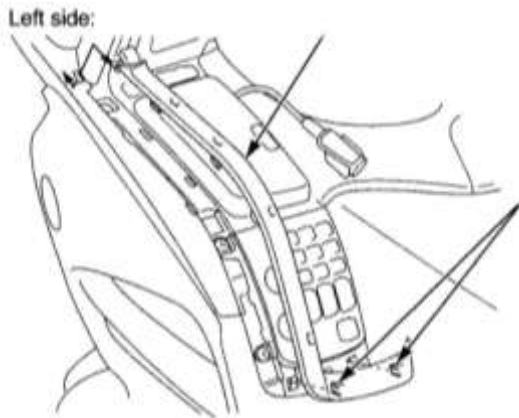

Figure 2

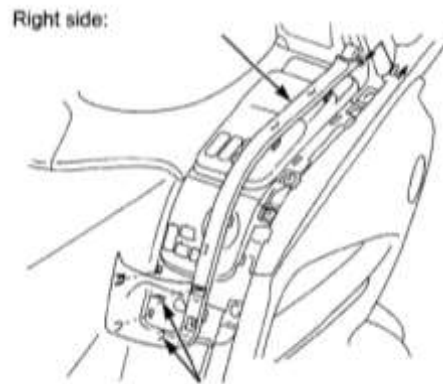

Figure 3

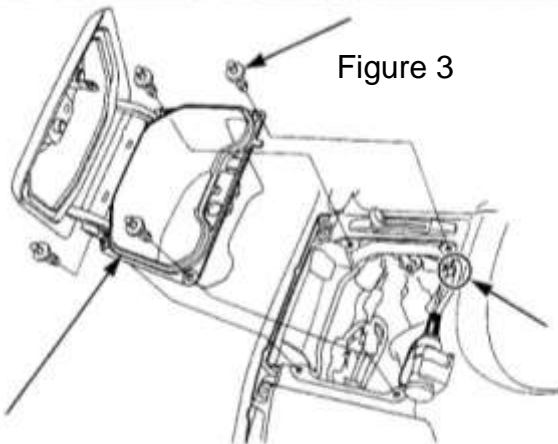

Figure 4



Figure 5



Logo trim light complete